

RAMBO-XPT DOBLE TANDEM

CIMESA



MATERIALES:

Acero Inoxidable 316
Hastelloy c-276
Monel K-500
Alloy 20
Carbón Grafitado
Carburo de Tungsteno
Carburo de Silicio
Todo tipo de juntas tóricas

LIMITES DE OPERACIÓN:

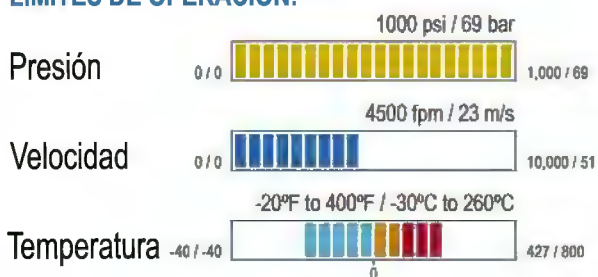

* Depende del sello secundario y materiales de las caras.



El RAMBO conforma la base de nuestro amplísimo PS MODULAR, para más de 5.000 aplicaciones.

Con el cambio de una camisa y un adaptador lo podemos convertir en un sello de máxima seguridad; en arreglo doble EN TANDEM.



TABLA DE DIMENSIONES

D1	D2	D3		D4	D5	D6	L1	L2	L5	A
		Min.	Max.							
1.125	1.697	1.875	2.000	2.312	4.250	2.312	3.304	2.273	1.031	0.437
1.250	1.875	2.000	2.125	2.562	4.250	2.312	3.304	2.273	1.031	0.437
1.375	1.937	2.125	2.250	2.687	4.250	3.250	3.304	2.273	1.031	0.473
1.500	2.187	2.250	2.500	2.687	4.875	3.250	3.321	2.273	1.048	0.437
1.625	2.312	2.375	2.625	2.937	5.000	3.625	3.414	2.366	1.048	0.437
1.750	2.437	2.500	3.500**	3.063	5.500	3.750	3.257	2.207	1.048	0.562
1.875	2.562	2.625	2.875	3.063	5.500	3.750	3.320	2.272	1.048	0.562
2.000	2.687	2.750	3.000	3.312	5.375	4.000	3.797	2.279	1.518	0.562

DIMENSIONES SUJETAS A CAMBIOS

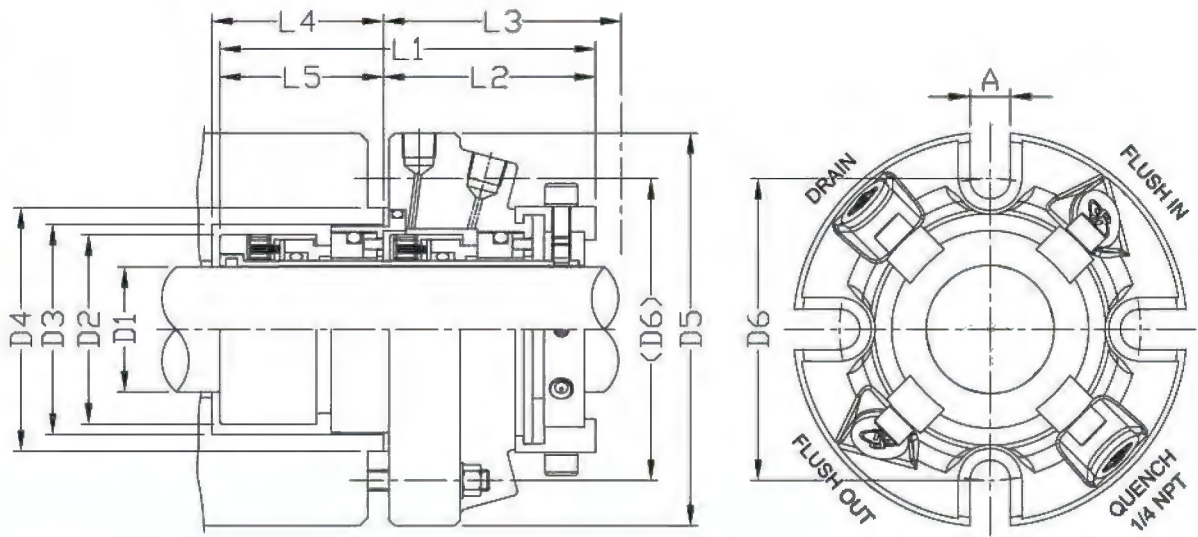